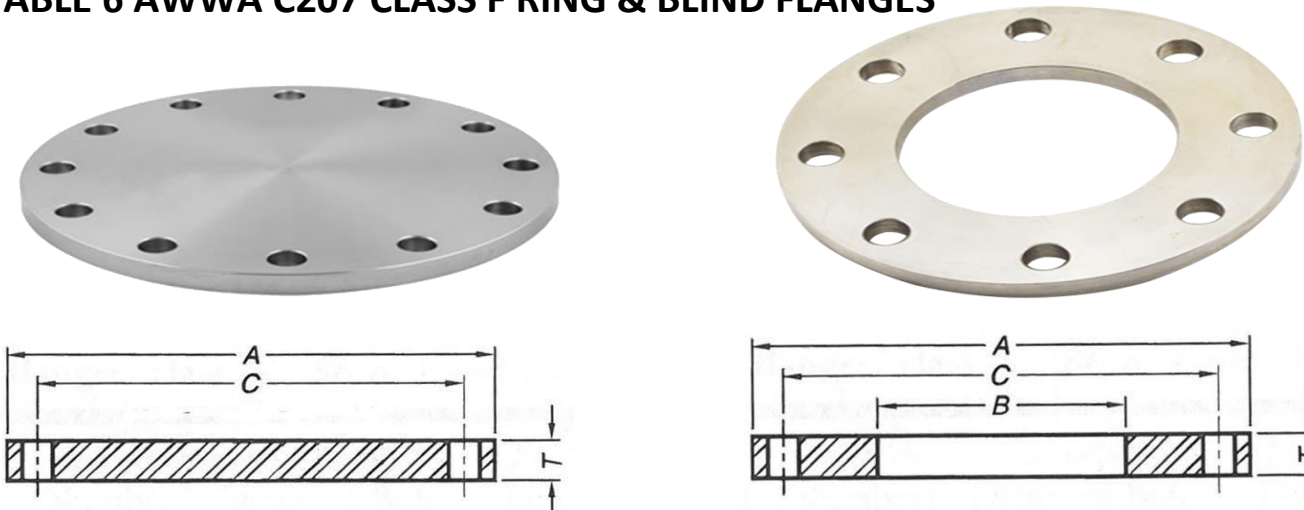

TABLE 6 AWWA C207 CLASS F RING & BLIND FLANGES



Nominal Pipe Size	O.D. Flange	Thickness		Bore	Drilling			Approx. Weight per Piece (LBS)	
		Slip On	Blind		Diam. of Bolt Circle	Diam. of Bolt Holes	Number of Bolts Holes	Slip On	Blind
NPS	A	T	T	B	C				
4	10	1.13	1.13	4.57	7.88	0.875	8	18	25
5	11	1.21	1.21	5.66	9.25	0.875	8	22	33
6	12.5	1.31	1.31	6.73	10.62	0.875	12	30	46
8	15	1.31	1.31	8.73	13	1	12	40	66
10	17.5	1.5	1.5	10.88	15.25	1.125	16	56	102
12	20.5	1.63	1.63	12.88	17.75	1.25	16	83	152
14	23	1.94	1.94	14.19	20.25	1.25	20	128	228
16	25.5	2.14	2.14	16.19	22.5	1.375	20	167	310
18	28	2.25	2.25	18.19	24.75	1.375	24	204	392
20	30.5	2.33	2.33	20.19	27	1.375	24	247	482
22	33	2.5	2.5	22.19	29.25	1.375	24	307	606
24	36	2.69	2.69	24.19	32	1.625	24	388	776
26	38.25	3	3	26.19	34.5	1.875	28	451	977
28	40.75	3.13	3.13	28.19	37	1.875	28	532	1156
30	43	3.15	3.166	30.19	39.25	1.875	28	586	1303
32	45.25	3.25	3.332	32.19	41.5	1.875	28	657	1518
34	47.5	3.38	3.475	34.19	43.5	1.875	28	741	1745
36	50	3.46	3.671	36.19	46	2.125	32	802	2042
38	52.25	3.5	3.815	38.19	48	2.125	32	874	2317
40	54.25	3.63	3.982	40.19	50.25	2.125	36	937	2608
42	57	3.81	4.171	42.19	52.75	2.125	36	1103	3015
44	59.25	4	4.338	44.19	55	2.125	36	1237	3388
46	61.5	4.13	4.505	46.19	57.25	2.125	40	1344	3791
48	65	4.5	4.781	48.19	60.75	2.125	40	1718	4494

Notes:

*Pressure rating at atmospheric temperature is 300 psi. These flanges have the same OD and drilling as ANSI/ASME B16.1 class 250 cast-iron pipe and flanged fittings. Dimensions are in inches. Weights are in pounds.